



FEATURES

- Digital communications console system
- Integrates telephone call handling and radio dispatch
- Resilient distributed architecture
- One to 15 operators, 28 line ports
- Supports and integrates analogue radio, MPT 1327, and TETRA voice and data
- Screen-based, configurable Graphical User Interface (GUI)
- Multilingual operator presentation
- IP connectivity option between two sites
- Range of operator and audio interface options

INTRODUCTION

The DCS-5020 Digital Console System is designed to meet the needs of the small to medium-sized operations control room. Combining telephony and both digital and analogue radio control, the DCS-5020 system supports combinations up to 28 ports and 15 screen-based operator consoles. The DCS-5020 meets a range of professional applications in public safety, emergency services, transportation, utilities and private industry. Offering many of the features of a traditional console system, the DCS-5020 is based on a distributed architecture which removes the requirement for a central switch, even with multiple operator positions. This ensures a fully scalable solution down to a single operator position and provides a high level of system resilience for mission critical applications. The built-in HTML browser capability supports access to additional operator applications such as GIS mapping and provides a means of accessing support information, such as procedures, telephone directories and video images.

DESCRIPTION

The DCS-5020 integrates telephony and radio, call handling, monitoring and logging functions into a single operator interface. The system supports up to 28 ports, with each assignable to telephone or radio circuits. There are up to 15 inter-linked operator positions, each comprising a host PC and video monitor, with desktop speakers. Optional accessories include headset, gooseneck/desk microphone, PTT footswitch, and keyboard.

The host PC runs Zetron's Windows®-based IntegratorDCS™ software, providing a graphical user interface (GUI) presenting the telephone/radio channels and system functions available to the operator. The video monitor can be full-size or compact LCD to fit control room requirements. Touchscreen and/or mouse/trackball control is available. The operator GUI is extensively configurable and screen text labels can be provided in a range of languages.

The desktop speakers and headset can be used to minimize desktop space requirements. The speakers—each with a volume control—are for active conversation (select) audio and monitored (unselect) audio. Optionally the DCS-5020 console can include an integrated Instant Recall Recording (IRR) capability that allows operator audio to be logged on the console PC with playback controlled from the GUI.

The digital switching and interface to the telephone and radio channels is through the compact DCS-5020 Digital Switch. Each Digital Switch supports up to six interface ports which can be allocated to console audio, telephone, or radio circuits. Additional ports are provided with additional Digital Switches linked together using one of the E1 Interconnect options, such as fibre, coaxial or twisted pair cable or linked over an IP network to a radio site or for a remote console location. The system architecture supports flexible system layout with operator positions and system resources being local to or remote from each other. Each interconnected Digital Switch and the interface ports on the switch are accessible from any other Digital Switch. In multiple position systems the radio and telephone resources on each switch may be shared in common with all positions in the system. In the unlikely event that a single Digital Switch fails, the only impact is on those operator, telephone and radio resources connected to that switch. All other shared resources continue to be available to the remaining positions.

By networking the operator console, PC's operators can access additional information services.

While networking of the console PC is not required for system operation, it will allow access to corporate directories, databases, and web-based services.

SAMPLE SYSTEM ARCHITECTURE

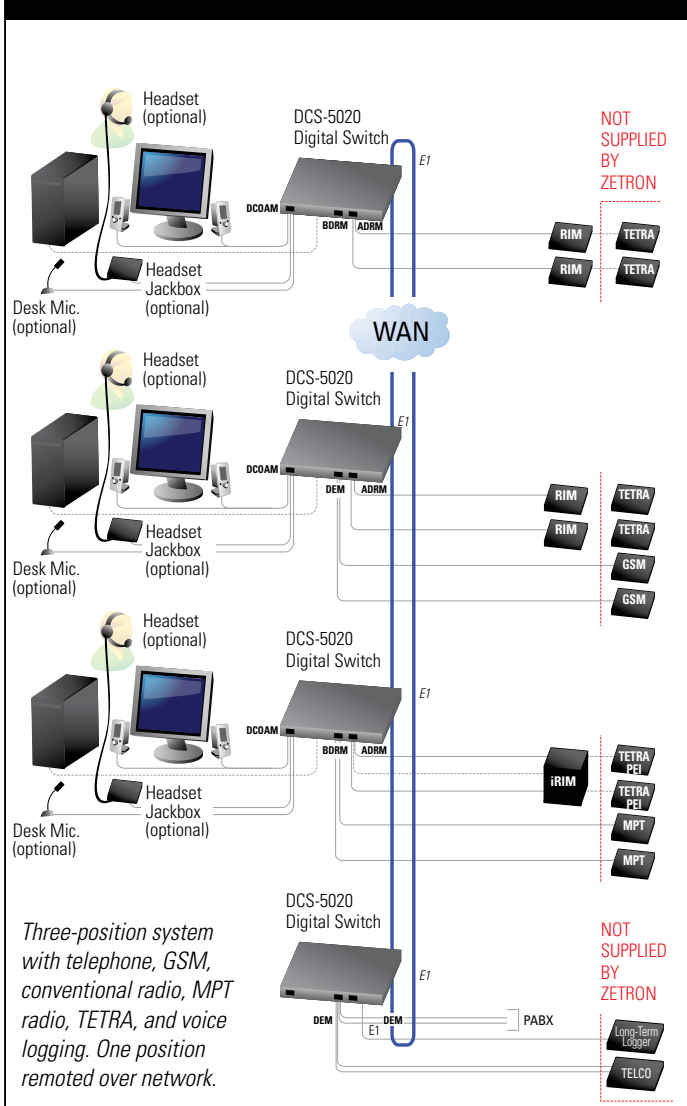

OPEN ARCHITECTURE

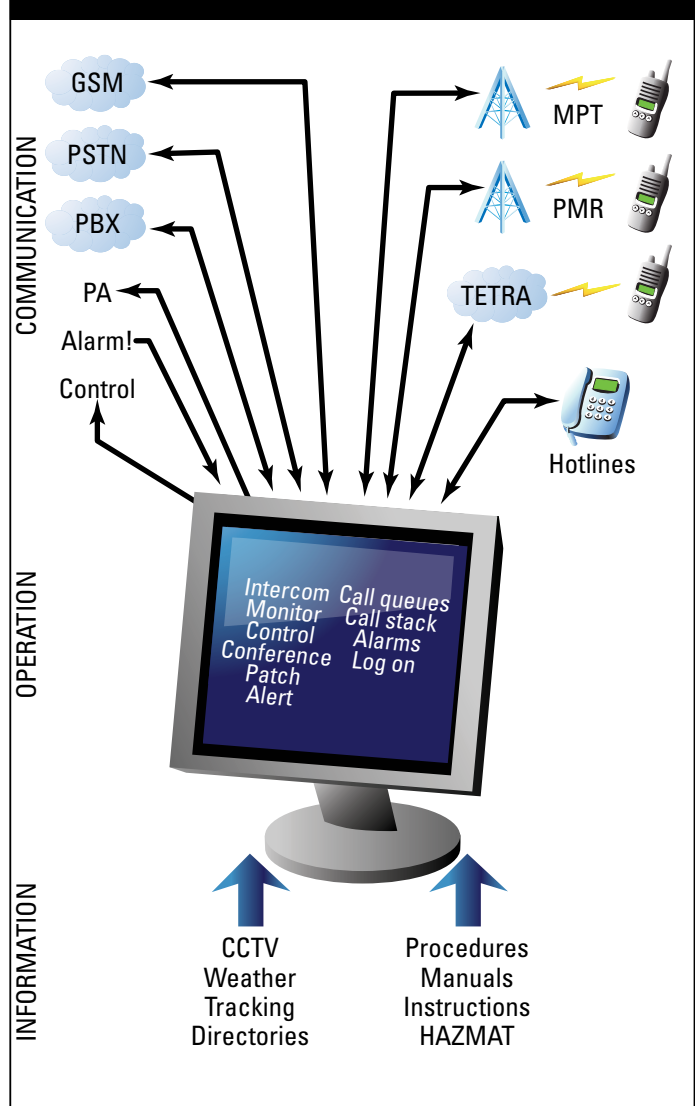

Zetron requires that certain minimum network performance criteria be met to provide IP connectivity. The IP option supports a maximum of two IP-connected sites.

DIGITAL SWITCH – MODULAR DESIGN

The required interfaces determine the choice of plug-in modules in the Digital Switch. Modules are currently available for the following:

- Analogue subscriber line or PABX extension level (or GSM networks with suitable gateway)
- Direct telephone connection or hot line circuits
- Conventional radio via 2/4-wire direct or Tone Remote Control (TRC)
- MPT 1327 via MAP27 interface or direct connect to Zetron MPT infrastructure
- Digital trunked TETRA radio via PEI or proprietary interface
- Compatible with Motorola, Nokia, Sepura TETRA radios - contact Zetron for details
- HF radio via an interface to Codan transceivers
- Analogue or E1 interface to long term voice logger

System installation and configuration is through the Digital Console Management System (DCMS) software. DCMS is used to set levels, download new firmware, and monitor the health of the system. Full time connection is required only if continuous monitoring is desired.



OPERATOR FUNCTIONS

Operator screen layouts can be configured to individual requirements, with on-screen graphics presenting line, function and status keys.

1. **Line** keys are assigned to individual ports—telephone, PABX, radio, intercom or pre-programmed working groups. Examples are:

- Analogue telephone line
- Telephone hunt group
- Conventional radio
- MPT 1327 radio/Zetron MPT 1327 infrastructure
- TETRA radio
- Direct Intercom line

2. **Function** keys allow the operator to select the specific operation, and include:

- Dial and Memory dial
- Answer next
- Clear
- Hold
- Multiline call
- Call transfer
- Radio/Radio and Radio/Telephone patch
- Monitor/unselect
- Volume control
- Radio selcall 5/6 tone
- Radio priority/busy channel marker
- Radio self repeat
- Individual/group call (MPT/TETRA)
- Emergency call (MPT/TETRA)
- TMO/DMO (TETRA)
- Send/receive status messages (TETRA)
- IRR playback
- Monitor digital inputs (e.g. external alarms)
- Control digital outputs (e.g. door latches)

3. The **status** area displays information about the console such as:

- Communications with the Digital Switch
- Audio mode—speakers/headset
- Date and Time

4. The **Call Stack** area displays lists of calls in various formats. The lists can include various data fields including time, date, call direction, call type, caller ID, unit status and call priority. Features include:

Started Date	Started Time	Priority	Console	Type	Radio Call Type	Line Name	Radio C
06/02/07	02:26:29 PM	Normal	Console 6	Radio	Unknown	radio 22	0
06/02/07	02:26:29 PM	Normal	Console 6	Radio	Unknown	radio 23	0
06/02/07	02:26:29 PM	Normal	Console 6	Radio	Unknown	radio 24	0
06/02/07	02:26:29 PM	Normal	Console 6	Radio	Unknown	radio 25	0
06/02/07	02:26:29 PM	Normal	Console 6	Radio	Unknown	radio 28	2
06/02/07	02:26:29 PM	Normal	Console 6	Radio	Unknown	radio 29	1

- Call Log list, showing a history of past calls.
- Unit Status list, showing the last transmission from each field unit.
- Call Queue list, showing field units who are requesting dispatcher attention.

- Optional buttons may be used to scroll through the list, remove calls from the list, and answer calls from the list.
- Field headers at the top of the list may be clicked to change the list sorting.

5. The **HTML** browser is a powerful feature which allows access to additional operator services and third party information such as:

- AVL application and Geographic Information Systems (GIS)
- Calling Line identity displaying calling line ID and name look up. (Contact Zetron for country-specific applications)
- Network files, e.g. procedures, directories and training
- Video streams, e.g. door access or CCTV
- Audio streams, e.g. voice logger
- Web or HTML based services, e.g. HAZMAT, weather

FLEXIBLE USER INTERFACE

Key to the DCS-5020's operational benefits is the flexibility of the GUI.

The Console Design tool allows the GUI to be designed to provide the required functionality and presentation format to meet the clients unique operational needs.

The GUI can be designed based on button, graphical and/or HTML presentation or a combination thereof.

For example:



Button



Graphic



HTML

Thumb TABs allow multiple pages to be provided. More frequently used buttons/information can be placed on the main screen/front page while lesser used resources can be placed behind. This and other GUI design resources allow the DCS-5020 GUI to be customised to provide the most effective and efficient GUI possible.

APPLICATIONS

The combination of telephony, conventional radio, MPT, and TETRA supports a range of console applications.

Small Control Rooms

The DCS-5020 is an economic solution for small control rooms for police, fire, ambulance, events, industry, ports and harbours. It brings many of the features of a large control centre into the smaller control room environment. The integrated radio and telephone functionality allows the operator to perform both call taking and dispatch functions. It can be employed as an incident control room without impacting on the role of the primary control centre.

(See Zetron Application Note : Small Control Rooms)

TETRA Wireless Console

The DCS-5020 offers innovative solutions to the growing TETRA community. It can connect to the TETRA system through a number of fixed TETRA radios, rather than through a direct connection to the TETRA infrastructure. A wireless console is preferred where direct connection to the infrastructure is not suitable for the application, too expensive, or not possible due to the location of the control room. The DCS-5020 can be fitted with the Model 232 Data/Voice Multiplexer to give access to remote fixed TETRA radios over an ISDN dial up or other bearers.

(See Zetron Application Note : TETRA Wireless Console)

Mobile Command Centre

Mobile command centres can be established for special events, accidents or other major incidents by deploying the DCS-5020 as a transportable package. The operator can have access to multiple MPT/TETRA working groups, conventional radio channels or telephone circuits to manage incident personnel. For truly transportable applications, the telephone ports may be fitted with GSM terminals for cellular telephony service.

(See Zetron Application Note : Mobile/Transportable Control Centres)

Fallback Control Centres

The DCS-5020 has a specific application for TETRA operators to ensure basic communications are maintained in the event of failure of key elements of the infrastructure. Failures of the network controller, links to repeater sites, or the primary control room are addressed by the DCS-5020 fallback solution which maintains critical communications between control room and field personnel.

(See Zetron Application Note : Enhanced Fallback Applications)

Call Centres with Mixed Technologies

For operators migrating from conventional to TETRA radio, the DCS-5020 provides a bridge enabling operators to manage both networks from a single position. Additionally, the operator can set up an interconnection or "patch" between the two networks so field personnel on one network can speak directly with the other.

SPECIFICATIONS

PHYSICAL

Digital Switch	45 mm (1.75") High (excluding 13 mm rubber feet)
	430 mm (17") Wide (excluding 19" rackmount brackets)
	240 mm (9.5") Deep (excluding cable exits)

ENVIRONMENTAL

Operating Temperature	0 to 50 degrees C
Storage Temperature	-10 to 60 degrees C
Humidity	95% RH at 45 degrees C, non-condensing
Power	85 to 260 Vac, 47 to 63 Hz. 96 VA max per device 12/24 VDC and 48VDC versions available

HOST PC REQUIREMENTS FOR INTEGRATOR DCS AND DCMS

Processor	Intel Pentium® IV or equivalent x86-class CPU, 2GHz
Operating system	Microsoft Windows® 2000 Service Pack 3 Microsoft Windows XP Professional
Memory	512 MB
Video	1024 x 768 resolution with a 16-bit color depth (65,536 colors)
Input Device	Keyboard, 2-button mouse
CD Drive	Required for installation
Network	10/100 Ethernet Connection (TCP/IP network protocol must be enabled) Only required for application features that support network operations.
.NET Framework	Microsoft .NET Framework 1.1 (included on installation media) Microsoft .NET Framework 2.0 (included on installation media)
DirectX	Microsoft DirectX 9.0c or later
PDF Reader	Adobe Acrobat Reader 7.0 or better (included on installation media) required for accessing electronic documentation

ZETRON USA

PO Box 97004
Redmond, WA
98073-9704
USA

TEL 425 820 6363

FAX 425 820 7031

zetron@zetron.com

ZETRON UK

27-29 Campbell Court
Bramley TADLEY
Basingstoke RG26 5EG
UK

TEL +44 (0)1256 880663

FAX +44 (0)1256 880491

uk@zetron.com

ZETRON AUSTRALASIA

PO Box 3045
Stafford Mail Centre
Stafford QLD 4053
Australia

TEL +61 7 3856 4888

FAX +61 7 3356 6877

ausales@zetron.com



© 2007 Zetron, Inc. All rights reserved. Zetron is a registered trademark of Zetron, Inc.

All trademarks are properties of their respective owners.