

- KFC-W112S -

Technical specifications

| | SYMBOL | UNIT | KFC-W112S |
|----------------------------|----------|-------|---------------|
| Nominal Impedance | Z | Ω | 8 |
| DC Resistance | Revc | Ω | 6.3 |
| Voice Coil Inductance | Levc | mH | 3.2 |
| Piston Area | Sd | sq.m | 0.048 |
| Force Factor | BL | T·m | 15.4 |
| Volume Acoustic Compliance | Vas | liter | 87.7 |
| | | cu.ft | 3.0 |
| Moving Mass | Mms | g | 119.5 |
| Resonance Frequency | Fs | Hz | 28 |
| Mechanical Q Factor | Qms | | 10.4 |
| Electrical Q Factor | Qes | | 0.613 |
| Total Q Factor | Qts | | 0.579 |
| Peak Power | W | | 800 |
| Peak Excursion | Xmax | mm | 7.7 |
| Displacement | | cc | 3511 |
| | | cu.ft | 0.124 |
| Mounting Depth | mm (in.) | | 141.6(5-9/16) |
| Weight of Magnet | g (oz) | | 1640(57.8) |
| Voice Coil Diameter | mm (in.) | | 50(1-15/16) |

Recommended Enclosures

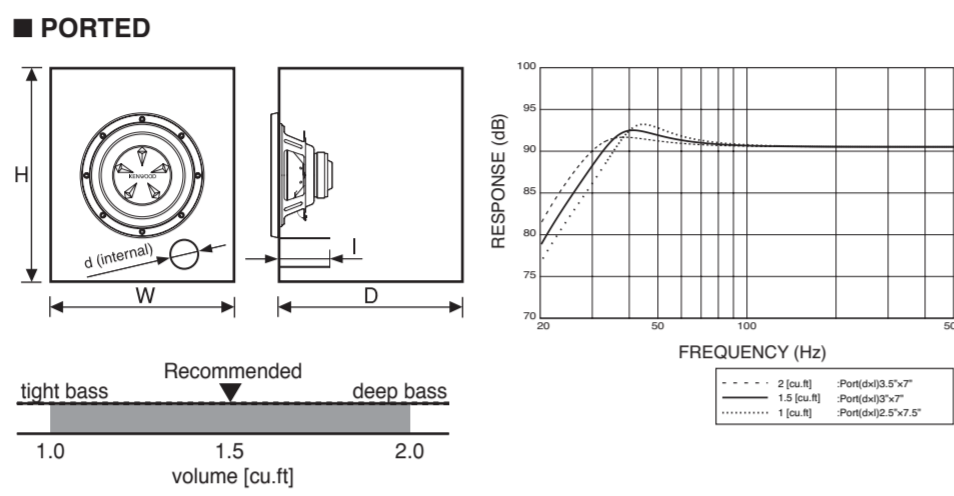
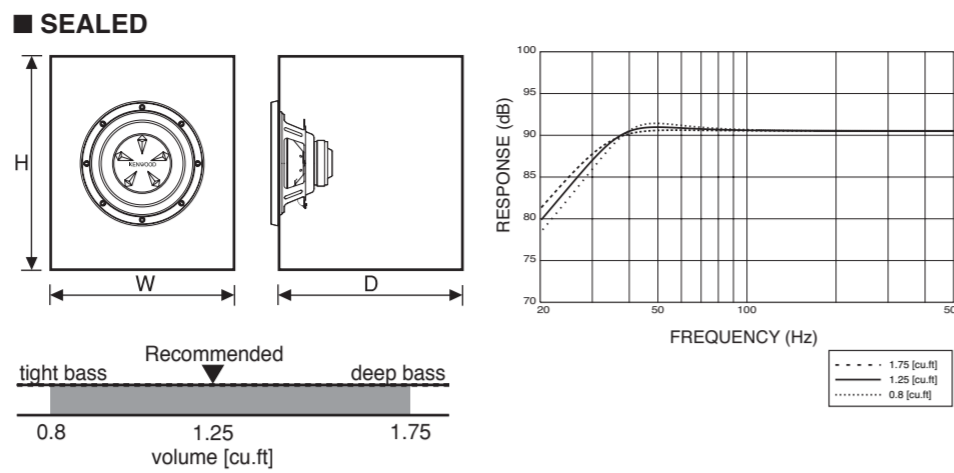

Recommended Enclosures *W, H, D.....External Dimensions

| Model Name | Volume | W | H | D | Mounting Hole | Port Diameter d | Port Length l | Displacement |
|------------|---------------|----------------|---------------|---------------|---------------|-----------------|---------------|--------------|
| KFC-W112S | 1.25 (35.4) | 380 (14-15/16) | 375 (14-3/4) | 360 (14-3/16) | 277 (10-7/8) | Sealed | Sealed | 0.124 |
| | 1.5 (42.5) | 380 (14-15/16) | 440 (17-5/16) | 360 (14-3/16) | | 76 (3) | 178 (7) | |
| (unit) | cu.ft (liter) | mm (in.) | | | | | | cu.ft |

Use 21 mm (3/4 inch) thick Medium Density Fiberboard (MDF) or High Density Particleboard.

- KFC-W110S -

Technical specifications

| | SYMBOL | UNIT | KFC-W110S |
|----------------------------|----------|-------|--------------|
| Nominal Impedance | Z | Ω | 8 |
| DC Resistance | Revc | Ω | 6.3 |
| Voice Coil Inductance | Levc | mH | 3.2 |
| Piston Area | Sd | sq.m | 0.035 |
| Force Factor | BL | T·m | 16 |
| Volume Acoustic Compliance | Vas | liter | 40.2 |
| | | cu.ft | 1.41 |
| Moving Mass | Mms | g | 112 |
| Resonance Frequency | Fs | Hz | 32 |
| Mechanical Q Factor | Qms | | 10.7 |
| Electrical Q Factor | Qes | | 0.591 |
| Total Q Factor | Qts | | 0.561 |
| Peak Power | W | | 700 |
| Peak Excursion | Xmax | mm | 7.7 |
| Displacement | | cc | 2294 |
| | | cu.ft | 0.081 |
| Mounting Depth | mm (in.) | | 123.8(4-7/8) |
| Weight of Magnet | g (oz) | | 1640(57.8) |
| Voice Coil Diameter | mm (in.) | | 50(1-15/16) |

Recommended Enclosures

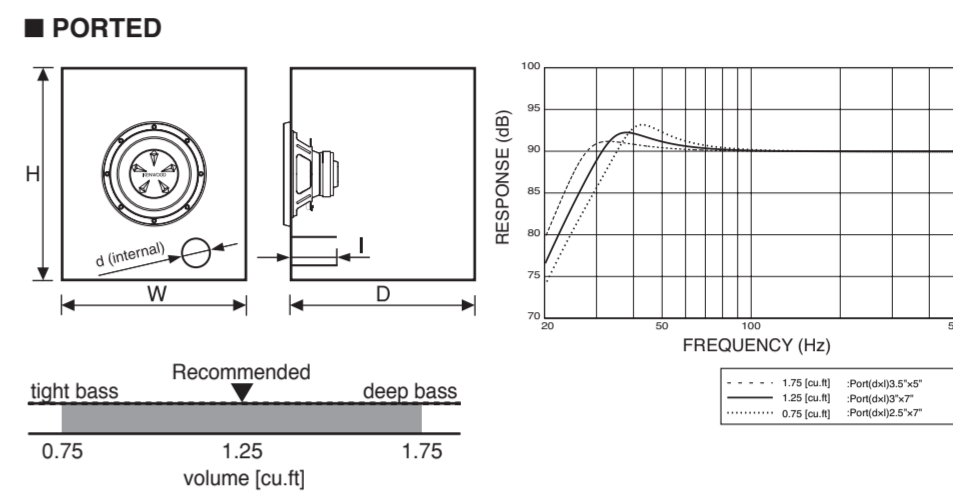
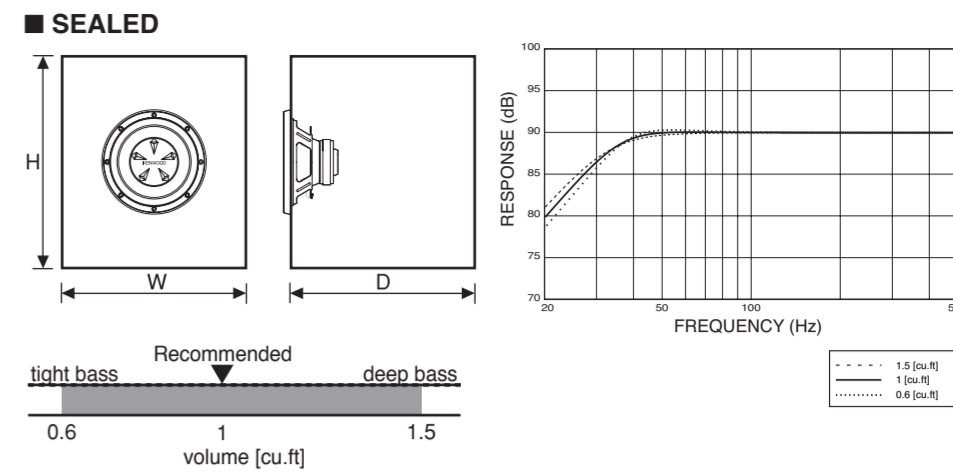

Recommended Enclosures *W, H, D.....External Dimensions

| Model Name | Volume | W | H | D | Mounting Hole | Port Diameter d | Port Length l | Displacement |
|------------|---------------|--------------|----------------|----------------|---------------|-----------------|---------------|--------------|
| KFC-W110S | 1 (28.3) | 330 (13) | 390 (15-3/8) | 325 (12-13/16) | 233 (9-3/16) | Sealed | Sealed | 0.081 |
| | 1.25 (35.4) | 340 (13-3/8) | 455 (17-15/16) | 330 (13) | | 76 (3) | 178 (7) | |
| (unit) | cu.ft (liter) | mm (in.) | | | | | | cu.ft |

Use 21 mm (3/4 inch) thick Medium Density Fiberboard (MDF) or High Density Particleboard.

- TEMPLATE
- GABARIT
- SCHABLONE
- SJABLOON
- MASCHERINA
- PLANTILLA

Parts included
Pièces comprises
Mitgeliefertes zubehör
Bijgeleverde onderde
Parti incluse
Partes incluidas

- φ4 × 25 (3/16 × 1) × 8
- × 1

